

# MI Preprint Series

Kyushu University  
The Global COE Program  
Math-for-Industry Education & Research Hub

## Abstract collision systems simulated by cellular automata

T. Ito,  
S.Inokuchi & Y.Mizoguchi

MI 2008-1

( Received September 2, 2008 )

Faculty of Mathematics  
Kyushu University  
Fukuoka, JAPAN

# Abstract collision systems simulated by cellular automata

Takahiro Ito<sup>1</sup>, Shuichi Inokuchi<sup>2</sup>, and Yoshihiro Mizoguchi<sup>2</sup>

<sup>1</sup> Graduate School of Mathematics, Kyushu University, JAPAN,

<sup>2</sup> Faculty of Mathematics, Kyushu University, JAPAN,

t-ito@math.kyushu-u.ac.jp

**Abstract.** We describe an algebraic transition system called an abstract collision system. An abstract collision system is an extension of a billiard ball system. Moreover, it is also an extension of a cellular automaton, a chemical reaction system and so on. We introduced an abstract collision system and investigated its properties [4]. In this paper, we study about simulation of abstract collision systems by cellular automata. It is impossible to simulate some abstract collision system. However, some of them can be easily simulated by a cellular automaton. First, we describe definitions of components of an abstract collision system. Next, we introduce how to construct a cellular automaton which simulates an abstract collision system. Finally, we investigate properties and conditions about simulations.

## 1 Introduction

Recently, there are many investigations about new computing frameworks which considered as the replacement of current electric computer devices and digital computers. One of main frameworks is the collision-based computing [1] which includes cellular automata and reaction-diffusion systems. We consider these new computing as a discrete transition system. Our purpose is constructing a computational models and investigating computational capabilities of those models.

Conway introduced 'The Game of Life' which used two-dimensional cellular automaton [2]. On 'The Game of Life', some patterns in cells called "gliders" are objects. Their collisions are brought by transitions of the cellular automaton. He showed that it can simulate any logical operations using "gliders". Wolfram and Cook [6, 3] found "glider" patterns in the one-dimensional elementary cellular automaton CA110. Cook introduced a cyclic tag system (CTS) as a Turing universal system. He proved that CTS was simulated by CA110. Recently, Morita [5] introduced a *reversible* one-dimensional cellular automaton which simulates CTS. We introduced an abstract collision system (ACS). It is an extension of a billiard ball system. Since it is defined as an abstract system, it is also an extension of a cellular automaton and a chemical reaction system. We proved some properties of these systems. In particular, we proved that a discrete billiard system is universal for computation [4].

In this paper, we consider simulation of abstract collision systems by cellular automata. It is impossible to simulate some abstract collision system. However, some of them can be easily simulated by a cellular automaton. In Section 2, we introduce an abstract collision system. Further, we reformulate a billiard ball system using our abstract collision system and prove their properties. In Section 3, we introduce how to construct a cellular automaton which simulates an abstract collision system. Further, we investigate properties and conditions about simulations.

First, we show an example. We consider chemical objects  $a, b$ , and  $c$ . We assume that they change within an unit time if they are particular state, for example the changing follows Table. 1.

**Table 1.** Transition rule

Before	After
'a'	'a', 'a'
'a', 'a'	'a', 'a', 'a'
'a', 'a', 'a', 'b'	'c'
'c'	'c', 'c'
'c', 'c'	'a', 'b'

We denote state which has one 'a' and one 'b' by  $\{A_1, B_1\}$ . Then an example of state transition is figured in Fig. 1.

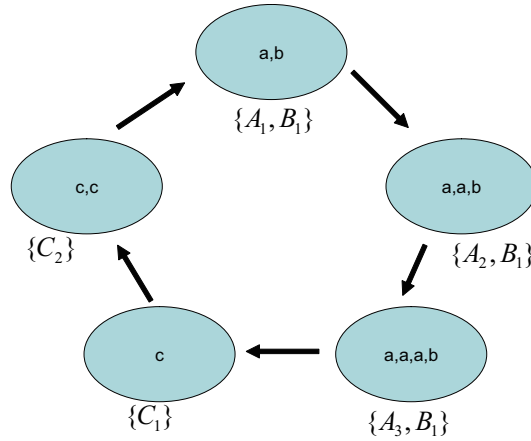

**Fig. 1.** Transition

Like this example, an abstract collision system can describe a reaction-diffusion system.

We show an example of a one-dimensional billiard ball system as ACS. A ball has a velocity, a label and a position. We consider discrete time transitions. A ball moves to left or right according its velocity within an unit time. Let  $(2, A, 1)$  be a ball with the velocity 2, the label 'A' and the position 1. At the next step, the ball becomes  $(2, A, 3)$  (cf. Fig. 2).

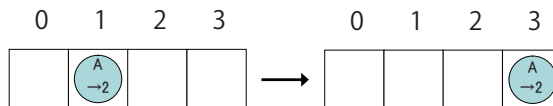

**Fig. 2.** Moving

That is the velocity and the label are same and only the position is changed. Some balls may crash in some unit time. In our paper, we do not describe a crash using positions and velocities. We define a set of balls which cause collisions and assign the result of the collisions. For example, a collision set is  $\{(2, A, 1), (-1, B, 2)\}$ . We define the result of the collision by a set  $\{(2, B, 3), (-1, A, 1)\}$  and write it as  $f(\{(2, A, 1), (-1, B, 2)\}) = \{(2, B, 3), (-1, A, 1)\}$  (cf. Fig. 3).



**Fig. 3.** Collision

We describe this example more concretely. Let  $V = \{-1, 2\}$  and  $S = \{(u, A, x) \mid x \in Z, u \in V\} \cup \{(v, B, y) \mid y \in Z, v \in V\}$ . We define a collision  $c$  and its result  $f(c)$  by Table. 2. Then, an example of transition is figured in Fig. 4.

**Table 2.** Collision and its result

$c$	$f(c)$
$\{(2, A, 1), (-1, B, 2)\}$	$\{(2, B, 3), (-1, A, 1)\}$
$\{(2, A, 1), (-1, B, 3)\}$	$\{(2, B, 3), (-1, A, 2)\}$
$\{(2, A, 1), (2, A, 2), (-1, B, 3)\}$	$\{(2, A, 3), (2, B, 4), (-1, A, 2)\}$
$\{(u, A, x)\}$	$\{(u, A, x + u)\}$
$\{(v, B, y)\}$	$\{(v, B, y + v)\}$

We note that  $\{(4, A, 2), (-1, B, 6)\}$  does not cause a collision, because it is not listed in the table. In this case, balls  $(4, A, 2)$  and  $(-1, B, 6)$  are applied transition rules which are in the bottom row of the table separately.

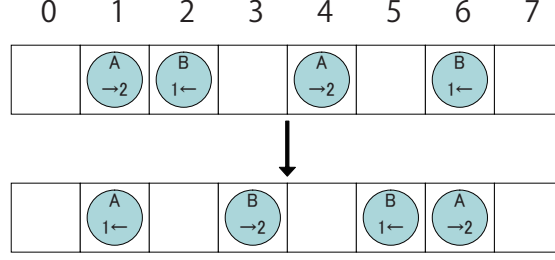

Fig. 4. Transition

## 2 An abstract collision system

In this section, we define an abstract collision system.

**Definition 1 (Set of collisions).** Let  $S$  be a non-empty set. A set  $\mathcal{C} \subseteq 2^S$  is called a **set of collisions** on  $S$  iff it has the following conditions:

- (SC1)  $s \in S \Rightarrow \{s\} \in \mathcal{C}$ .
- (SC2)  $X_1, X_2 \in \mathcal{C}, X_1 \cap X_2 \neq \phi \Rightarrow X_1 \cup X_2 \in \mathcal{C}$ .
- (SC3)  $A \in 2^S, p \in A \Rightarrow [p]_{\mathcal{C}}^A \in \mathcal{C}$

where  $[p]_{\mathcal{C}}^A := \cup \{X \mid X \in \mathcal{C}, p \in X, X \subseteq A\}$ .

We note that the condition (SC3) can be omitted if  $\mathcal{C}$  is a finite set.

**Proposition 1.** Let  $\mathcal{C}$  be a set of collisions on  $S$ . For any  $A \in 2^S$  and  $p, q \in A$ , we have the followings:

- (1)  $[p]_{\mathcal{C}}^A \neq \phi$ .
- (2)  $[p]_{\mathcal{C}}^A \cap [q]_{\mathcal{C}}^A \neq \phi \Rightarrow [p]_{\mathcal{C}}^A = [q]_{\mathcal{C}}^A$ .

*Proof.* (1) Since  $\{p\} \in \mathcal{C}$ ,  $p \in \{p\}$  and  $\{p\} \subseteq A$ , we have  $\{p\} \subseteq [p]_{\mathcal{C}}^A$ . Hence  $[p]_{\mathcal{C}}^A \neq \phi$ .

(2) We assume  $[p]_{\mathcal{C}}^A \cap [q]_{\mathcal{C}}^A \neq \phi$ . Since  $[p]_{\mathcal{C}}^A, [q]_{\mathcal{C}}^A \in \mathcal{C}$ ,  $p \in [p]_{\mathcal{C}}^A \cup [q]_{\mathcal{C}}^A \in \mathcal{C}$  and  $[p]_{\mathcal{C}}^A \cup [q]_{\mathcal{C}}^A \subseteq A$ , we have  $[p]_{\mathcal{C}}^A \cup [q]_{\mathcal{C}}^A \subseteq [p]_{\mathcal{C}}^A$ . Hence  $[p]_{\mathcal{C}}^A = [p]_{\mathcal{C}}^A \cup [q]_{\mathcal{C}}^A$ . Similarly, we have  $[q]_{\mathcal{C}}^A = [p]_{\mathcal{C}}^A \cup [q]_{\mathcal{C}}^A$ . Hence  $[p]_{\mathcal{C}}^A = [q]_{\mathcal{C}}^A$ .

**Definition 2 (An abstract collision system).** Let  $S$  be a non-empty set and  $\mathcal{C}$  be a set of collisions on  $S$ . Let  $f : \mathcal{C} \rightarrow 2^S$ . We define an **abstract collision system**  $M$  by  $M = (S, \mathcal{C}, f)$ . We call the function  $f$  and the set  $2^S$  a **local transition function** and a **configuration** of  $M$ , respectively. We define a **global transition function**  $\delta_M : 2^S \rightarrow 2^S$  of  $M$  by

$$\delta_M(A) = \cup \{f([p]_{\mathcal{C}}^A) \mid p \in A\}.$$

**Proposition 2.** For a given binary relation  $R_S$  on  $S$ , we define  $\mathcal{C}[R_S]$  by

$$\mathcal{C}[R_S] := \cap \left\{ \mathcal{C} \mid \begin{array}{l} \mathcal{C} \text{ is a set of collisions on } S \text{ such that} \\ (x, y) \in R_S \Rightarrow \{x, y\} \in \mathcal{C} \end{array} \right\}.$$

Then  $\mathcal{C}[R_S]$  is a set of collisions on  $S$ .

*Proof.* (1) Let  $s \in S$  and  $\mathcal{C}$  be a set of collisions on  $S$ . Then we have  $\{s\} \in \mathcal{C}$  by **(SC1)**. Hence  $\{s\} \in \mathcal{C}[R_S]$ .

(2) Let  $X_1, X_2 \in \mathcal{C}[R_S]$  with  $X_1 \cap X_2 \neq \emptyset$ . Let  $\mathcal{C}$  be a set of collisions on  $S$  such that  $(x, y) \in R_S \Rightarrow \{x, y\} \in \mathcal{C}$ . Since  $X_1, X_2 \in \mathcal{C}$ , we have  $X_1 \cup X_2 \in \mathcal{C}$  by **(SC2)**. Hence  $X_1 \cup X_2 \in \mathcal{C}[R_S]$ .

(3) Let  $A \in 2^S$  and  $p \in A$ . Let  $\mathcal{C}$  be a set of collisions on  $S$  such that  $(x, y) \in R \Rightarrow \{x, y\} \in \mathcal{C}$ . Since  $\mathcal{C}[R_S] \subseteq \mathcal{C}$ , we have  $[p]_{\mathcal{C}[R_S]}^A \subseteq [p]_{\mathcal{C}}^A \in \mathcal{C}$  by **(SC3)**. Hence  $[p]_{\mathcal{C}[R_S]}^A \in \mathcal{C}[R_S]$ .

Next we define a discrete billiard system as a special case of an abstract collision system.

**Definition 3.** Let  $L$  be a finite set of labels,  $V$  be a finite subset of  $\mathbb{Z}$  and  $B = V \times L \times \mathbb{Z}$ . We define a binary relation  $R_B$  on the set  $B$  by

$$((v_l, a_l, x_l), (v_r, a_r, x_r)) \in R_B \Leftrightarrow 0 < \frac{x_r - x_l}{v_l - v_r} \leq 1.$$

**Definition 4 (Shift).** For any  $X \in 2^B$  and  $d \in \mathbb{Z}$ , the  $d$ -shift of  $X$ , which is denoted by  $X + d$ , is defined by

$$X + d := \{(v, a, x + d) \mid (v, a, x) \in X\}.$$

We define a binary relation  $R_{shift}$  on  $B$  as follows:

$(X_1, X_2) \in R_{shift}$  iff there exists  $d \in \mathbb{Z}$  such that  $X_2 = X_1 + d$ .

**Proposition 3.** This relation  $R_{shift}$  is an equivalence relation.

*Proof.* Since

- (1)  $X = X + 0$ ,
- (2)  $X_2 = X_1 + d \Rightarrow X_1 = X_2 + (-d)$  and
- (3)  $X_2 = X_1 + d_1, X_3 = X_2 + d_2 \Rightarrow X_3 = X_1 + (d_1 + d_2)$ ,

it is clear that  $R_{shift}$  is an equivalence relation.

**Definition 5 (Complete system of representatives).**

For the above set  $B$  and the relation  $R_B$ , consider a set

$$\cup \{b \mid [b] \in \mathcal{C}[R_B]/R_{shift}\}$$

of representative elements. It is not determined uniquely. However, we take one of such sets and denote it by  $\mathcal{F}[B]$ , and call it **complete system of representatives** of  $\mathcal{C}[R_B]/R_{shift}$ .

**Definition 6 (A discrete billiard system).** A discrete billiard system is defined by  $M' = (B, \mathcal{F}[B], f_{\mathcal{F}[B]})$ , where  $f_{\mathcal{F}[B]} : \mathcal{F}[B] \rightarrow 2^B$  has

$$f_{\mathcal{F}[B]}(\{(v, a, x)\}) = \{(v, a, x + v)\},$$

and we call the function a **local transition function** of  $M'$ . Moreover, we define a function  $\hat{f}_{M'} : \mathcal{C}[R_B] \rightarrow 2^B$  by

$$\hat{f}_{M'}(X + d) = f_{\mathcal{F}[B]}(X) + d \quad (\text{for } X \in \mathcal{F}[B], d \in \mathbb{Z}). \quad (1)$$

We define a **global transition function**  $\delta_{M'} : 2^B \rightarrow 2^B$  of  $M'$  by that of an abstract collision system  $(B, \mathcal{C}[R_B], \hat{f}_{M'})$ .

**Definition 7 (Simple billiard system).** Let  $B = V \times L \times \mathbb{Z}$ , and  $M' = (B, \mathcal{F}[B], f_{\mathcal{F}[B]})$  be a discrete billiard system. We call  $M'$  a **simple billiard system** (or **perfectly elastic billiard system**) iff the local transition function  $f_{\mathcal{F}[B]}$  has

$$f_{\mathcal{F}[B]}(X) = \{(v, a', x + v) \mid (v, a, x) \in X\} \quad (a, a' \in L).$$

### 3 Simulation by cellular automata

In this section, we describe simple billiard systems which are simulated by cellular automata.

**Definition 8 (A cellular automaton).** Let  $r$  be a non-negative integer,  $Q$  be a non-empty finite set of states of cells, and  $f : Q^{2r+1} \rightarrow Q$  be a local transition function. A **cellular automaton** with radius  $r$  (or  $2r + 1$  neighborhood cellular automaton)  $C$  is defined by  $C = (Q, f)$ . A **configuration** of  $C$  is a mapping  $q : \mathbb{Z} \rightarrow Q$ . The set of all configurations is denoted by  $\text{Conf}(C)$ . A **global transition function**  $\delta_C : \text{Conf}(C) \rightarrow \text{Conf}(C)$  of  $C$  is defined by

$$\delta_C(q)(i) = f(q(i-r), \dots, q(i-1), q(i), q(i+1), \dots, q(i+r)) \quad \text{for any } i \in \mathbb{Z}$$

Next, we consider simulations of simple billiard systems by cellular automata. The most easy example is a simple billiard system that all balls have same velocity. We can easily translate this one into a cellular automaton.

**Proposition 4.** Let  $V = \{v\}$ ,  $L$  be a finite set,  $B = V \times L \times \mathbb{Z}$ , and  $M_1$  be a simple billiard system  $M_1 = (B, \mathcal{F}[B], f_{\mathcal{F}[B]})$ . Then, there exists a cellular automaton with radius  $|v|$  ( $2|v| + 1$  neighborhood)  $C_1 = (Q_1, f_1)$  and bijection  $\pi_1 : 2^B \rightarrow \text{Conf}(C_1)$  such that

$$\begin{aligned} \pi_1 \circ \delta_{M_1}^t(A) &= \delta_{C_1}^t \circ \pi_1(A), \\ \pi_1^{-1} \circ \delta_{C_1}^t(q) &= \delta_{M_1}^t \circ \pi_1^{-1}(q), \end{aligned} \quad (2)$$

where  $\delta_{M_1}$  and  $\delta_{C_1}$  are global transition function of  $M_1$  and  $C_1$ , respectively.

*Proof.* On this simple billiard system  $M_1$ , balls never cause collision, that is  $R_B = \phi$ . Hence  $\mathcal{C}[R_B] = \{\{s\} \mid s \in B\}$ . By definition of a discrete billiard system, for any  $A_0 \in 2^B$  and  $t \in \mathbb{N}$ ,

$$\delta_{M_1}^t(A_0) = \{(v, a, x + v \times t) \mid (v, a, x) \in A_0\}.$$

We define a cellular automaton  $C_1 = (\{\varepsilon\} \cup L, f_1)$ , where  $\varepsilon \notin L$  and

$$f_1(x_{-|v|}, \dots, x_{-1}, x_0, x_1, \dots, x_{|v|}) = x_{-v}.$$

For any configuration  $q \in \text{Conf}(C_1)$ , integer  $i \in \mathbb{Z}$ , and positive integer  $t \in \mathbb{N}$ , the global transition function  $\delta_{C_1}$  has

$$\delta_{C_1}^t(q)(i) = q(i - v \times t).$$

Moreover, we define a bijection  $\pi_1 : 2^B \rightarrow \text{Conf}(C_1)$  by

$$\pi_1(A)(i) = \begin{cases} a & \text{if } (v, a, i) \in A \\ \varepsilon & \text{otherwise} \end{cases} \quad (3)$$

Then, we have

$$\pi_1^{-1}(q) = \{(v, q(i), i) \mid q(i) \neq \varepsilon \text{ (i.e., } q(i) \in L)\}, \quad (4)$$

and they have Eq. (2).

**Corollary 1.** *Especially, if  $\#L = 1$  and  $V = \{v\}$ ,  $|v| \leq 1$  then the simple billiard system corresponds to 1-dimensional, 2-state, 3-neighborhood cellular automaton.*

**Table 3.** Velocity  $v$  and Rule number of CA.

Velocity $v$	Rule number
-1	170
0	204
+1	240

Next example is a simple discrete billiard system but there are some collisions.

**Proposition 5.** *Let  $V = \{0, 1\}$ ,  $L = \{a_0\}$ ,  $B = V \times L \times \mathbb{Z}$ , and  $M_2$  be a simple billiard system  $M_2 = (B, \mathcal{F}[B], f_{\mathcal{F}[B]})$ . Then, there exists a cellular automaton with radius 1 (3 neighborhood)  $C_2 = (Q_2, f_2)$  and bijection  $\pi_2 : 2^B \rightarrow \text{Conf}(C_2)$  such that*

$$\begin{aligned} \pi_2 \circ \delta_{M_2}^t(A) &= \delta_{C_2}^t \circ \pi_2(A), \\ \pi_2^{-1} \circ \delta_{C_2}^t(q) &= \delta_{M_2}^t \circ \pi_2^{-1}(q), \end{aligned} \quad (5)$$

where  $\delta_{M_2}$  and  $\delta_{C_2}$  are global transition function of  $M_2$  and  $C_2$ , respectively.

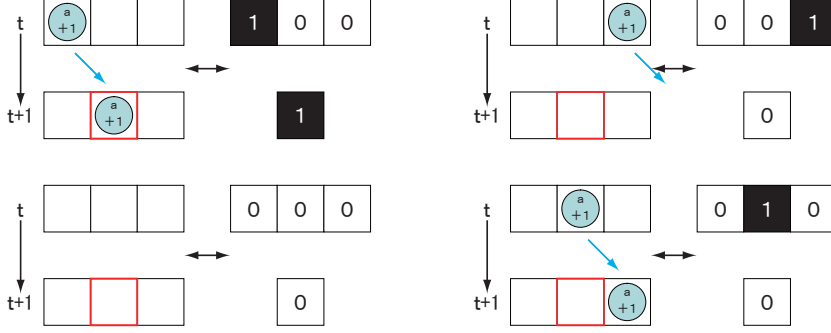

**Fig. 5.** Behavior of the discrete billiard system (left side), and local transition function of the cellular automaton (right side).

*Proof.* We compute a set of collisions  $\mathcal{C}[R_B]$ , and it is

$$\mathcal{C}[R_B] = \{\{b\} \mid b \in B\} \cup \{(1, a_0, x-1), (0, a_0, x)\} \mid x \in \mathbb{Z}\}.$$

We take a complete system of representatives  $\mathcal{F}[B]$  as follows:

$$\mathcal{F}[B] = \{(0, a_0, 0)\}, \{(1, a_0, 0)\}, \{(1, a_0, 0), (0, a_0, 1)\}.$$

Since  $M_2$  is simple billiard system, the local transition function  $f_{\mathcal{F}[B]}$  is

$$\begin{aligned} f_{\mathcal{F}[B]}(\{(0, a_0, 0)\}) &= \{(0, a_0, 0)\}, \\ f_{\mathcal{F}[B]}(\{(1, a_0, 0)\}) &= \{(1, a_0, 1)\}, \\ f_{\mathcal{F}[B]}(\{(1, a_0, 0), (0, a_0, 1)\}) &= \{(1, a_0, 1), (0, a_0, 1)\}. \end{aligned} \quad (6)$$

Then the global transition function  $\delta_{M_2}$  has followings:  
for any  $A_0 \in 2^B$  and  $t \in \mathbb{N}$ ,

$$\delta_{M_2}^t(A_0) = \{(v, a, x + v \times t) \mid (v, a, x) \in A_0\}.$$

We define a cellular automaton  $C_2 = (Q_2, f_2)$ ,  $Q_2 = \{0, 1, 2, 3\}$ , where  $f_2$  is given by Table 4.

For any configuration  $q \in \text{Conf}(C_2)$ , integer  $i \in \mathbb{Z}$ , and positive integer  $t \in \mathbb{N}$ , the global transition function  $\delta_{C_2}$  has

$$\delta_{C_2}^t(q)(i) = 2^0 \times [q(i)]_0 + 2^1 \times [q(i-1 \times t)]_1,$$

where  $[q(i)]_k \in \{0, 1\}$  is a  $k$ -th digit of binary number representation of  $q(i)$ , that is

$$q(i) = 2^0 \times [q(i)]_0 + 2^1 \times [q(i)]_1.$$

We define a map  $\pi_2$  by

$$\pi_2(A)(i) = \begin{cases} 3 & \text{if } (0, a_0, i), (1, a_0, i) \in A, \\ 2 & \text{if } (0, a_0, i) \notin A, (1, a_0, i) \in A, \\ 1 & \text{if } (0, a_0, i) \in A, (1, a_0, i) \notin A, \\ 0 & \text{otherwise,} \end{cases} \quad (7)$$

**Table 4.** The local function  $f_2$  of the cellular automaton  $C_2$ 

$(x, y, z)$	$f(x, y, z)$	$(x, y, z)$	$f(x, y, z)$
$(0, 0, z)$	0	$(2, 0, z)$	2
$(0, 1, z)$	1	$(2, 1, z)$	3
$(0, 2, z)$	0	$(2, 2, z)$	2
$(0, 3, z)$	1	$(2, 3, z)$	3
$(1, 0, z)$	0	$(3, 0, z)$	2
$(1, 1, z)$	1	$(3, 1, z)$	3
$(1, 2, z)$	0	$(3, 2, z)$	2
$(1, 3, z)$	1	$(3, 3, z)$	3

then they have Eq. (5).

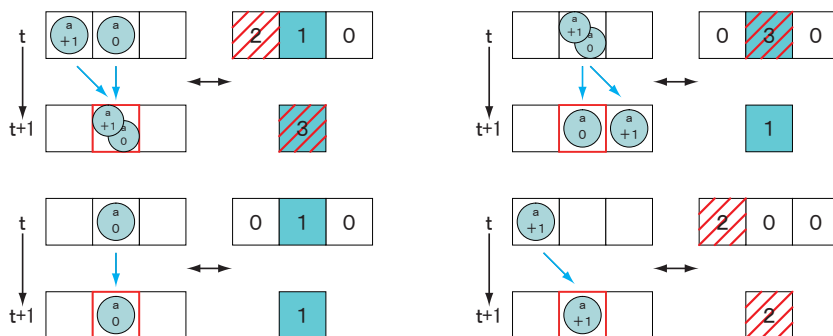
**Fig. 6.** Behavior of the discrete billiard system, and local transition function of the cellular automaton.

Let  $L$  be a finite set,  $V$  be a finite subset of  $\mathbb{Z}$ ,  $B = V \times L \times \mathbb{Z}$ , and  $M$  be a simple billiard system  $M = (B, \mathcal{F}[B], f_{\mathcal{F}[B]})$ . We put  $v_{max} = \max\{|v| \mid v \in V\}$ . Then the simple billiard system  $M$  seems to be simulated by a cellular automaton with radius  $v_{max}$  ( $2v_{max} + 1$  neighborhood). However, there is a counter-example.

**Lemma 1.** *Let  $V = \{v_1, v_2\}$ ,  $v_2 - v_1 > 1$ ,  $L$  be a finite set,  $B = V \times L \times \mathbb{Z}$ . Then there is a simple billiard system  $M_3 = (B, \mathcal{F}[B], f_{\mathcal{F}[B]})$  which can not be simulated by any cellular automaton with finite radius.*

*Proof.* We show the case of  $v_2 - v_1 = 4$ . We can prove other cases similarly.

Let  $V = \{1, 5\}$ ,  $L$  be a finite set,  $B = V \times L \times \mathbb{Z}$ , and  $M_3$  be a simple billiard system  $M_3 = (B, \mathcal{F}[B], f_{\mathcal{F}[B]})$ . Then, the set of collisions  $\mathcal{C}[R_B]$  has following

sets:

$$\begin{aligned}
X_2 &= \{(5, b, -5), (1, a, -4)\}, \\
X_3 &= \{(5, b, -5), (1, a, -4), (5, b, -7)\}, \\
X_4 &= \{(5, b, -5), (1, a, -4), (5, b, -7), (1, a, -6)\}, \\
X_{2n} &= \{(5, b, -2i - 3), (1, a, -2j - 2) \mid i, j = 1, 2, \dots, n\}, \\
X_{2n+1} &= \left\{ (5, b, -2i - 3), (1, a, -2j - 2) \mid \begin{array}{l} i = 1, \dots, n+1, \\ j = 1, \dots, n \end{array} \right\}.
\end{aligned} \tag{8}$$

We take a complete system of representatives  $\mathcal{F}[B]$  which has these sets. Moreover, we define the local transition function  $f_{\mathcal{F}[B]}$  by

$$\begin{aligned}
f_{\mathcal{F}[B]}(X_2) &= \{(5, a, 0), (1, b, -3)\}, \\
f_{\mathcal{F}[B]}(X_3) &= \{(5, b, 0), (1, a, -3), (5, b, -2)\}, \\
f_{\mathcal{F}[B]}(X_4) &= \{(5, a, 0), (1, a, -3), (5, b, -2), (1, b, -5)\}, \\
f_{\mathcal{F}[B]}(X_{2n}) &= \left\{ (5, b, -2i + 2), (1, a, -2j - 1) \mid \begin{array}{l} i = 2, 3, \dots, n, \\ j = 1, 2, \dots, n-1 \end{array} \right\} \\
&\quad \cup \{(5, a, 0), (1, b, -2n - 1)\}, \\
f_{\mathcal{F}[B]}(X_{2n+1}) &= \left\{ (5, b, -2i + 2), (1, a, -2j - 1) \mid \begin{array}{l} i = 1, 2, \dots, n+1, \\ j = 1, 2, \dots, n \end{array} \right\}
\end{aligned} \tag{9}$$

On this situation, we cannot determine a state of cell of position 0, with only radius 5 (11 neighborhood). For example, by comparing two sets  $X_2$  and  $X_3$ , we

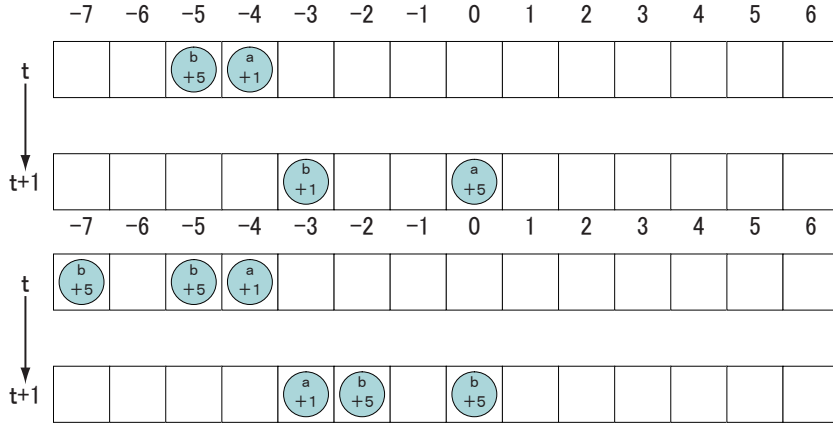

**Fig. 7.**

found that configurations in neighborhood with radius 5 are equal. However, the state of ball which appear in the position 0 is different (cf. Fig. 7). Similarly,  $X_{2n}$  and  $X_{2n+1}$  have same situation. So we need information of an infinite number of cells to determine the state of position 0.

We investigated that some of simple billiard systems can be simulated by cellular automata and others can not. Therefore, it is problem that what kind of system can be simulated. If an infinite number of balls cause collision like above counter-example, it is impossible to simulate by cellular automata with finite radius. So we should investigate what conditions need to simulate. In this paper, we give constraints to velocity of each ball.

**Theorem 1.** *Let  $L$  be a finite set,  $V = \{v_1, v_2\}$ ,  $B = V \times L \times \mathbb{Z}$ , and  $M$  be a simple billiard system  $M = (B, \mathcal{F}[B], f_{\mathcal{F}[B]})$ . If  $v_2 - v_1 = 1$ , that is  $V = \{v_1, v_1 + 1\}$  then, a set of collisions  $\mathcal{C}[R_B]$  does not have any infinite set. On the contrary, if  $v_2 - v_1 > 1$ ,  $\mathcal{C}[R_B]$  has infinite sets.*

*Proof.* If  $v_2 - v_1 > 1$ ,  $\mathcal{C}[R_B]$  has an infinite set as follows:

$$\{(v_2, a_k, (v_2 - v_1 - 1)k), (v_1, b_k, (v_2 - v_1 - 1)k + 1) \mid k \in \mathbb{Z}, a_k, b_k \in L\}.$$

On the other hand, if we assume that  $v_2 - v_1 = 1$ , then we have

$$R_B = \{((v + 1, a, x), (v, b, x + 1)) \mid x \in \mathbb{Z}, a, b \in L\}.$$

We set  $\mathcal{C}_0$  by

$$\begin{aligned} \mathcal{C}_0 &= \{ \{(v, a, x)\} \mid (v, a, x) \in B \} \\ &\cup \left\{ b_l \cup b_r \mid b_l \in 2^{(1, L, x)}, b_r \in 2^{(0, L, x+1)}, x \in \mathbb{Z} \right\}, \\ L(v_0, x_0) &:= \{(v_0, a, x_0) \mid a \in L\}, \\ 2^{(v_0, L, x_0)} &:= 2^{L(v_0, x_0)} \setminus \phi. \end{aligned}$$

We note that if  $(b_l, b_r) \in R_B$ , then one of two sets  $\{b_l\}$  and  $\{b_r\}$  is an element of  $2^{(1, L, x)}$  and the other is an element of  $2^{(0, L, x+1)}$ . Therefore, a set  $\mathcal{C}_0$  has

$$(x, y) \in R_B \Rightarrow \{x, y\} \in \mathcal{C}_0,$$

and  $\mathcal{C}_0$  is a set of collisions. It says that

$$\mathcal{C}[R_B] \subset \mathcal{C}_0.$$

We note that  $\mathcal{C}_0$  does not have any infinite set. Hence  $\mathcal{C}[R_B]$  does so.

## 4 Conclusion

In this paper, we described properties of an abstract collision system. We investigated if a cellular automaton can simulate a simple billiard system which is one of abstract collision systems. We proved that some of simple billiard system corresponded to a cellular automaton.

On the other hand, there are simple billiard systems which has collisions of an infinite number of balls. It is impossible to simulate such systems by cellular automata with finite radius. We describe one condition to simulate simple billiard systems by cellular automata.

However, if an infinite number of balls cause collision, some properties of local transition function may enable simulation. We should investigate these conditions.

## References

1. A. Adamtzky (Ed)., *Collision-Based Computing*, Springer, 2002.
2. E.R. Berlekamp, J.H.Conway and R.Guy, *Winning Ways for Your Mathematical Plays*, vol 2, Academic Press, 1982.
3. M. Cook. *Universality in elementary cellular automata*, Complex Systems, 15, p1-40 (2004).
4. T. Ito, S. Inokuchi, and Y. Mizoguchi, *An abstract collision system*, AUTOMATA-2008 Theory and Applications of Cellular Automata, pp 339-355, Luniver Press, 2008.
5. K. Morita. *Simple universal one-dimensional reversible cellular automata*, Journal of Cellular Automata, Vol 2, pp 159-166 (2007).
6. S. Wolfram. *A New Kind of Science*. (Wolfram Media, 2002).

# List of MI Preprint Series, Kyushu University

The Global COE Program  
Math-for-Industry Education & Research Hub

MI

2008-1 Takahiro Ito, Shuichi Inokuchi & Yoshihiro Mizoguchi  
Abstract collision systems simulated by cellular automata